

# DEUTZ TCD 3.9 / 4.0



TCO optimized solutions for  
highest emission requirement

## TCD 3.9 / 4.0

- Max. power: 129,4 kW (2300 rpm)
- Max. torque: 700 Nm (1300 rpm – 1600 rpm)
- Fuel consumption: 198 g/kWh



**AGRI  
TECHNICA**<sup>®</sup>  
THE WORLD'S NO. 1

[www.agritechnica.deutz.com](http://www.agritechnica.deutz.com)

# DEUTZ TCD 3.9 / 4.0



## Characteristics Industry engine

### Target Engine Specification

- Cylinder 4 inline
- Displacement 3.94 l
- Bore / Hub 99 / 128 mm
- Max. Power 129,4 kW (2300 rpm)
- Max. Torque 700 Nm (1300 – 1600 rpm)
- Multi-Power Label available
- Turbocharger pneumatic actuator w/ solenoid valve
- Side PTO 1 160 Nm
- Side PTO 2 310 Nm
- B10T 8,000 Std. (construction use)
- Service Interval 500 h / 1,000 h optional
- Start-Stop-System available

### EAT Specification:

- **Stage V & Tier 4 final:**
- DOC/DPF + SCR / w/o EGR
- **Stage IIIA (R96):**
- w/o EAT / with EGR

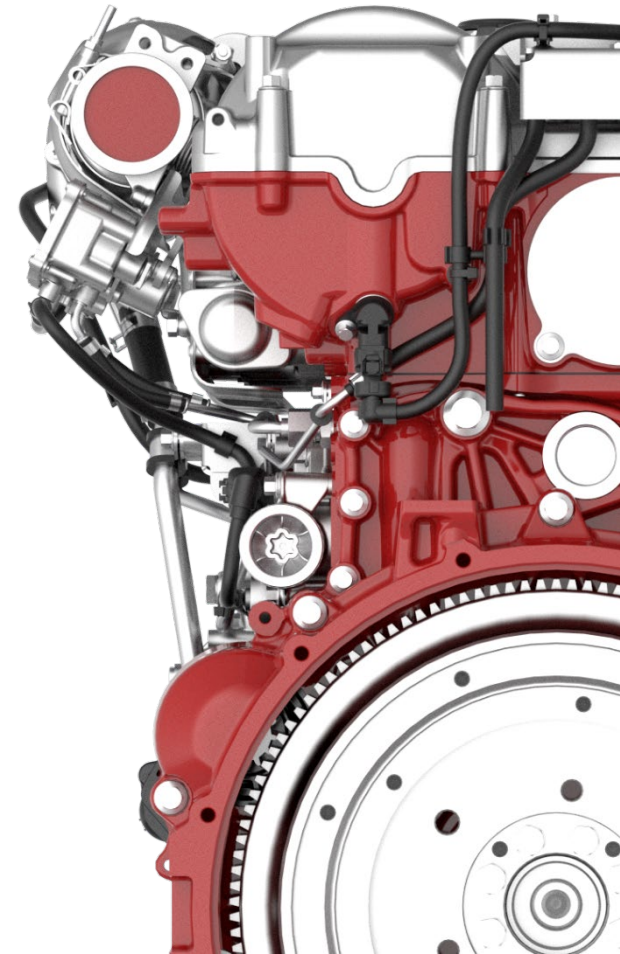

# DEUTZ TCD 3.9 / 4.0



## Characteristics value and performance variant

	TCD 3.9	TCD 4.0
	Standard	Performance
Power	75 – 110 kW	110 – 129,4 kW
Max. Torque	642 Nm	700 Nm
Aftertreatment (Stage V & Tier 4F)	DOC/DPF + SCR w/o EGR	

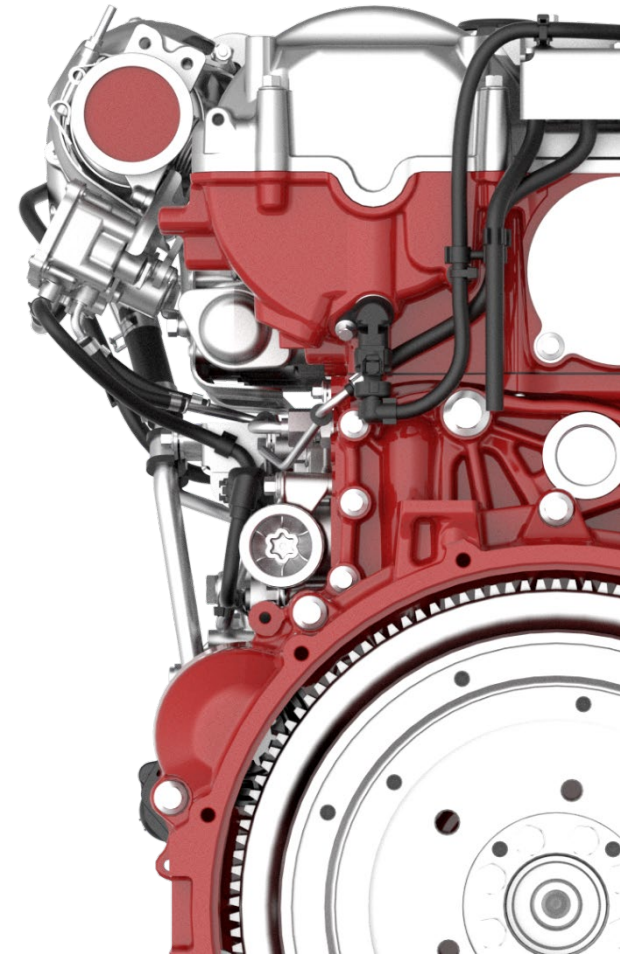

# DEUTZ TCD 3.9 / 4.0



Mounted EAT

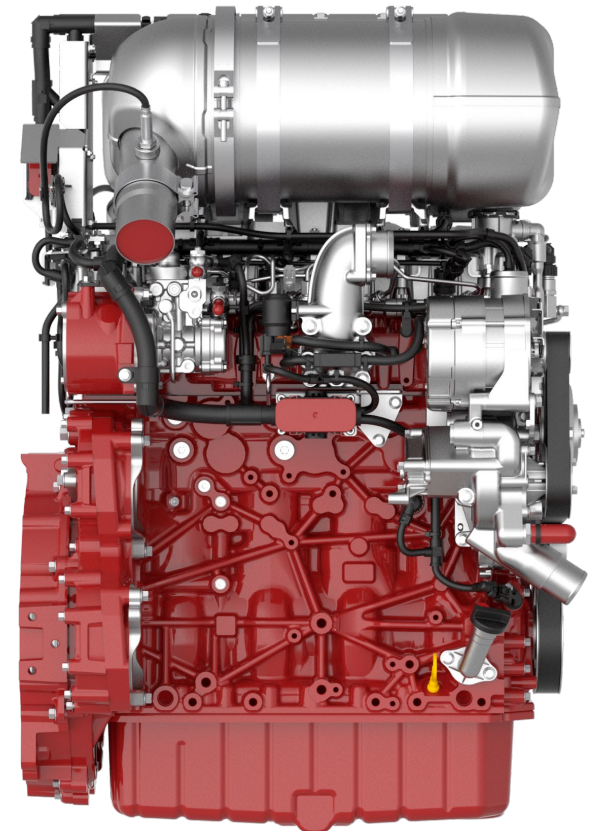
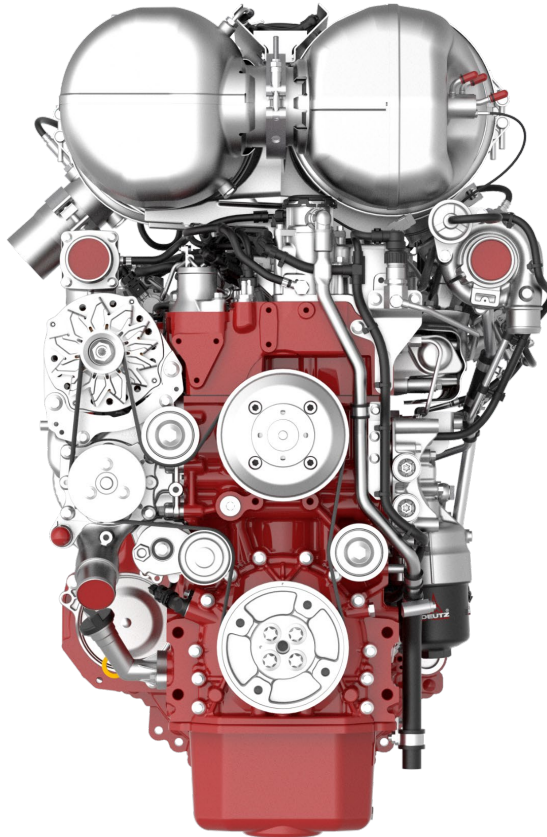
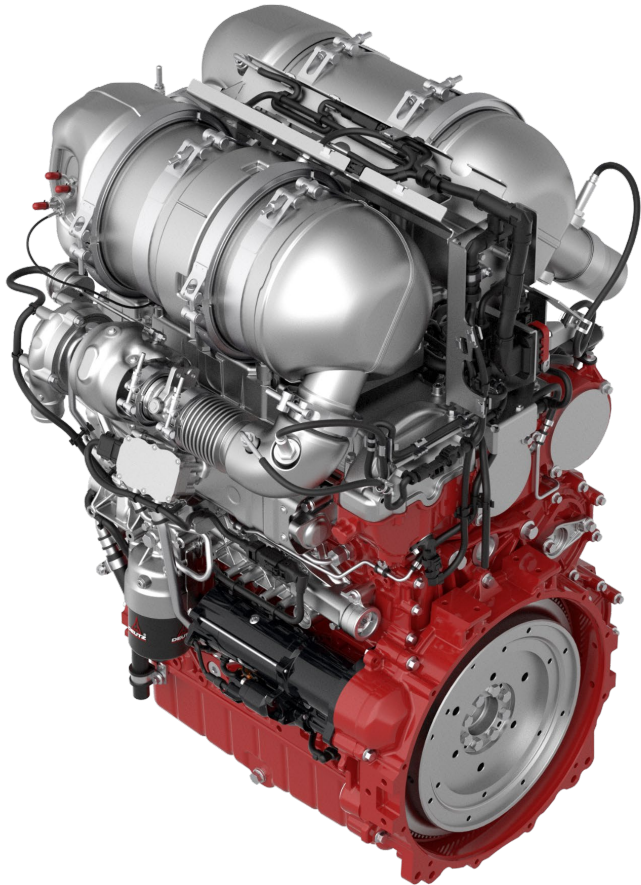

# DEUTZ TCD 3.9 / 4.0



## Dimensions

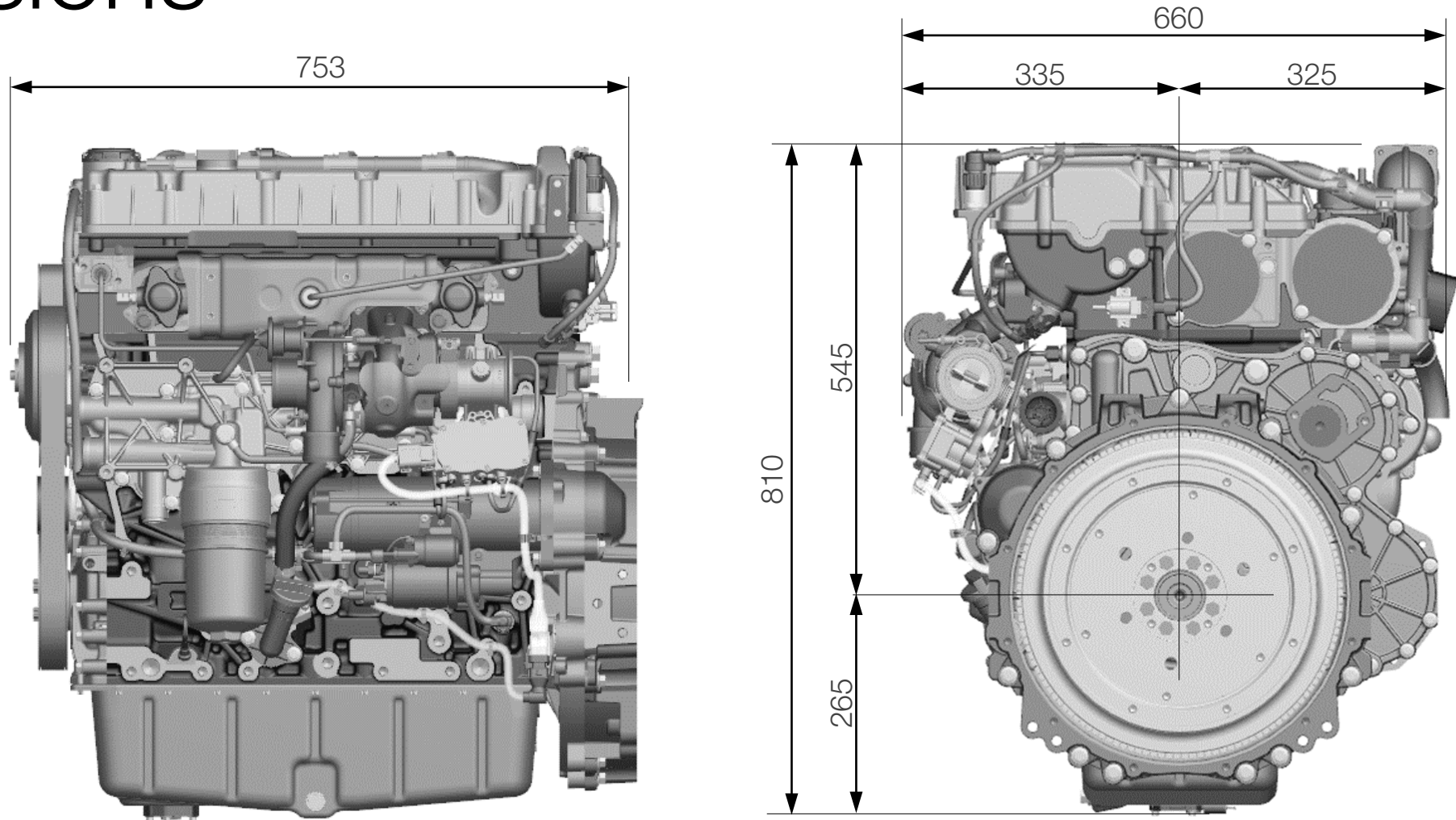

# DEUTZ TCD 3.9 preliminary



## Engine performance curve

- Engine Type **TCD 3.9 L4 Value**
- Power acc. to ISO14396
- Rated power 110 kW / 2300 rpm
- Max. torque 642 Nm / 1600 rpm
  
- Engine Type **TCD 3.6 L4**
- Power acc. to ISO14396
- Rated power 105 kW / 2300 rpm
- Max. torque 550 Nm / 1600 rpm

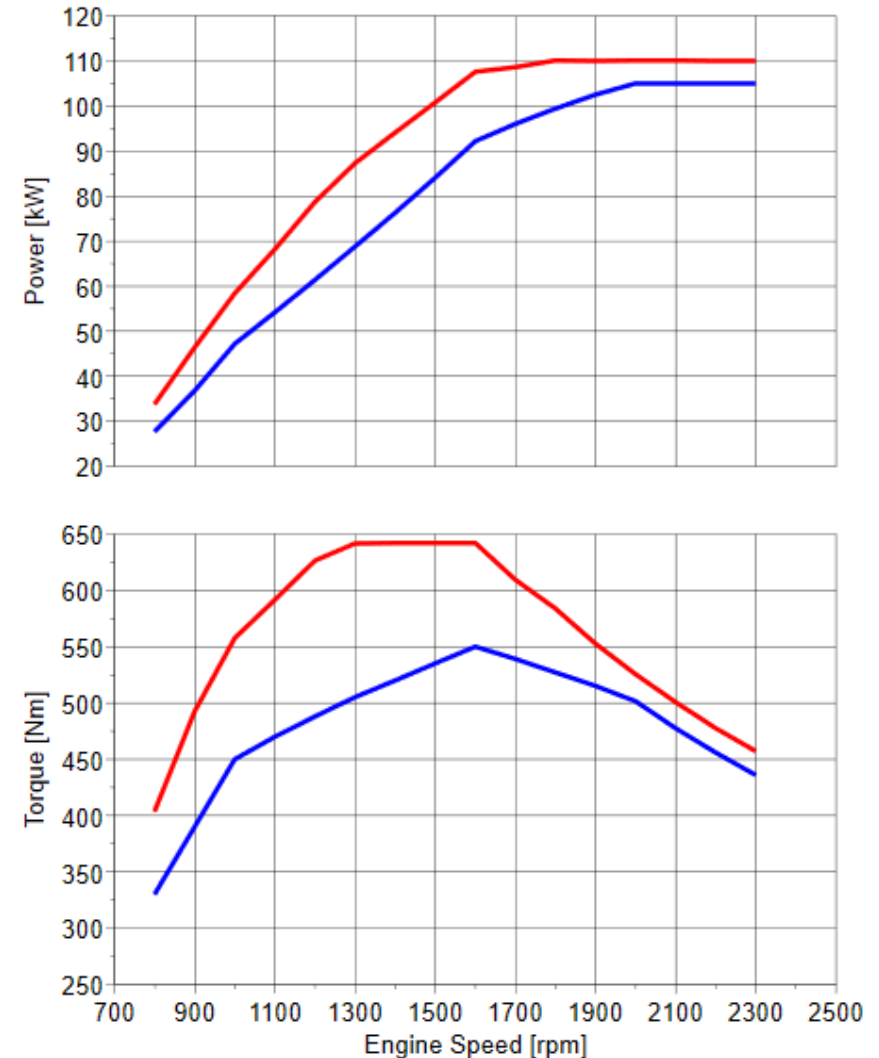

# DEUTZ TCD 4.0 preliminary



## Engine performance curve

- Engine Type **TCD 4.0 L4 Performance**
- Power acc. to ISO14396
- Rated power 129,4 kW / 2300 rpm
- Max. torque 700 Nm / 1600 rpm
  
- Engine Type **TCD 4.1 L4**
- Power acc. to ISO14396
- Rated power 115 kW / 2300 rpm
- Max. torque 609 Nm / 1600 rpm

