

DEUTZ TCD 7.8 L6

Powerful, efficient and compact.



For mobile machinery

The TCD 7.8 – With 160 up to 260 kW power output ideal for your application.

- **POWERFUL** / Up to 260 kW & 1400 Nm
- **LOW EMISSIONS** / EU Stage V, US Tier 4, CN IV ready & HVO ready
- **MODULAR** / Wide range of applications due to a variety of options
- **VERSATILE** / Agricultural & EDG – version (Stage IIIA, US Tier 3)*
- **POWERPACK** / Modular, compact & ready for installation

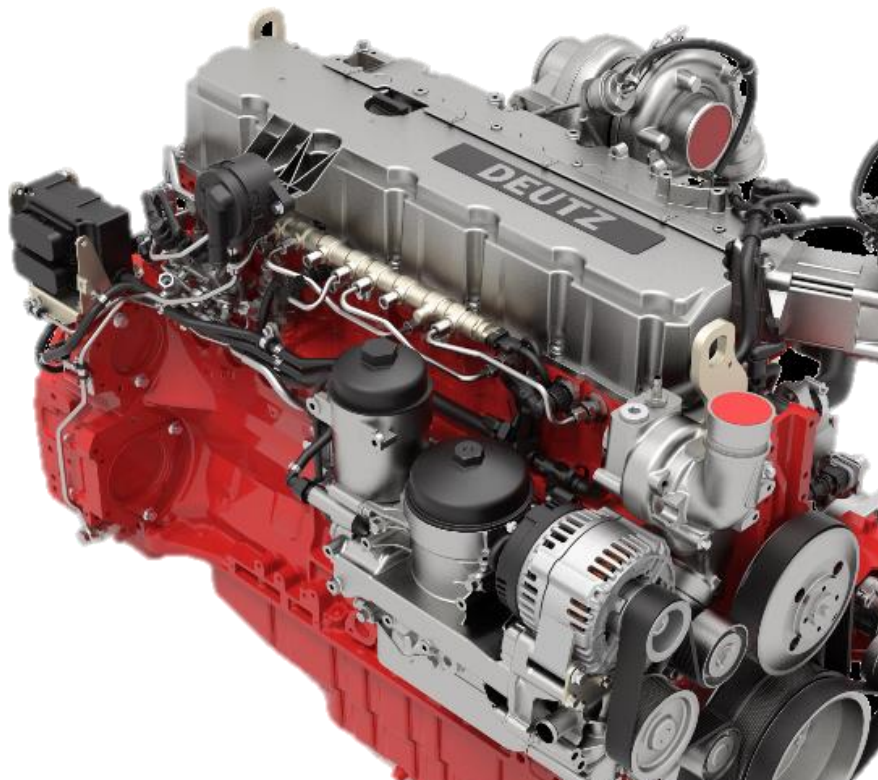

*Emission Downgrade without EAT

DEUTZ TCD 7.8

— TCD 7.8

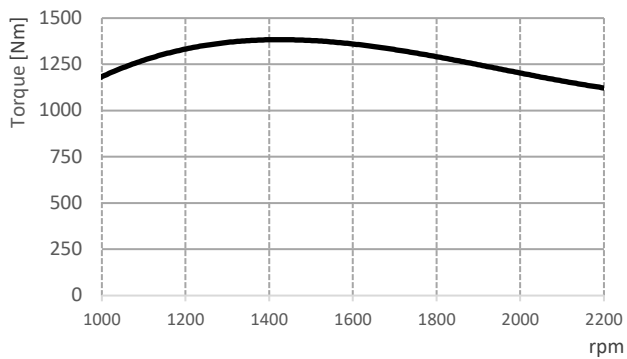
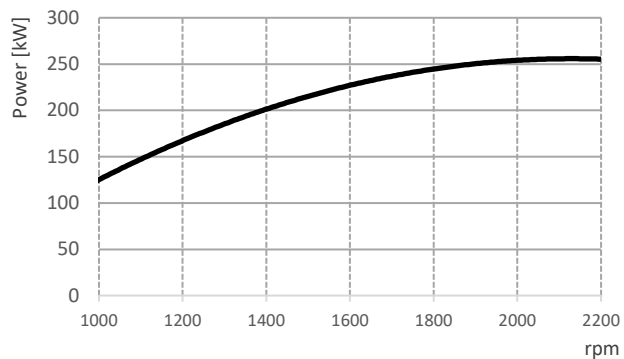

TECHNICAL DATA

| ENGINE TYPE | TCD 7.8 | |
|-----------------------------|-------------------------------------|-----------|
| No. of Cylinders | 6 | |
| Displacement | l | 7.755 |
| Max. Nominal Speed | min ⁻¹ | 2300 |
| Aspiration | Turbocharger with charge air cooler | |
| Power Output acc. ISO 14396 | kW | 160 - 260 |
| At Speed | min ⁻¹ | 2300 |
| Max. Torque | Nm | 1400 |
| At Speed | min ⁻¹ | 1450 |
| Min. Idling Speed | min ⁻¹ | 800 |
| Weight (DIN 70020 Part 7A) | kg | 725 |

DIMENSIONS

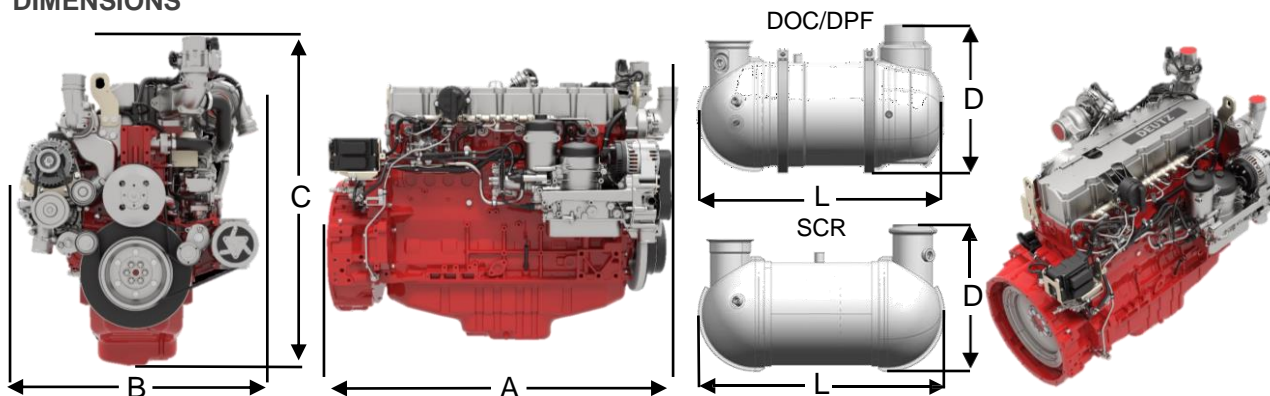

| ENGINE TYPE | mm | DOC/DPF | | | | SCR | | | DOC/DPF | SCR |
|-------------|----|---------|-----|------|-----|-----|-----|-----|---------|-----|
| | | A | B | C | D | L | D | L | | |
| TCD 7.8 | mm | 1214 | 842 | 1062 | 318 | 816 | 318 | 775 | ● ■ | ● ■ |

- Standard for US Tier 4
- Standard for EU Stage V



DEUTZ AG
 Ottostraße 1
 51149 Cologne
 Germany
www.deutz.com