

DEUTZ TCD 6.1 L6

Powerful, efficient and compact.



For mobile machinery

The TCD 6.1 – With 105 up to 180 kW power output ideal for your application.

- **POWERFUL** / Up to 180 kW & 1000 Nm
- **LOW EMISSIONS** / EU Stg. V, US Tier 4, CN IV ready & HVO ready
- **MODULAR** / Wide range of applications due to a variety of options
- **VERSATILE** / Agricultural & EDG – version (Stage IIIA, Tier 3)*
- **POWERPACK** / Modular, compact & ready for installation



*Emission Downgrade without EAT

DEUTZ TCD 6.1

— TCD 6.1

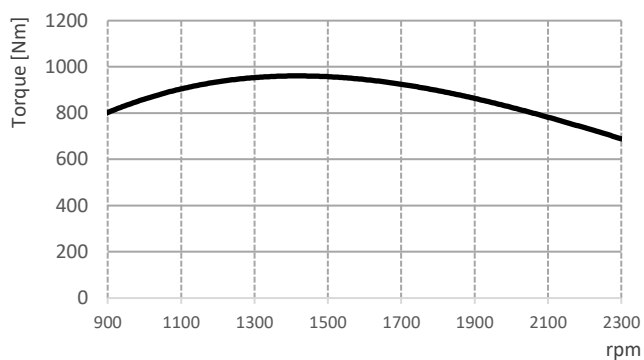
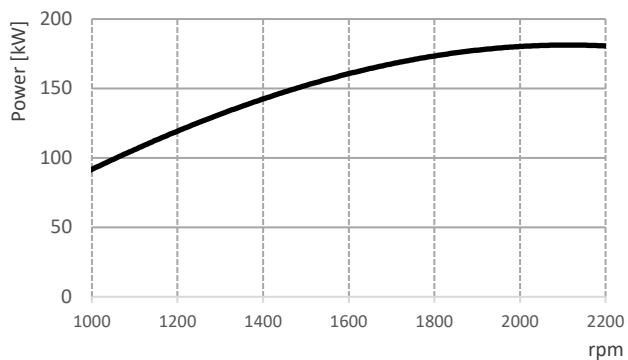

TECHNICAL DATA

| ENGINE TYPE | TCD 6.1 | |
|-----------------------------|-------------------------------|-------------|
| No. of Cylinders | 6 | |
| Displacement | l | 6.057 |
| Max. Nominal Speed | min ⁻¹ | 2300 |
| Aspiration | Turbocharger with intercooler | |
| Power Output acc. ISO 14396 | kW | 105 - 180 |
| At Speed | min ⁻¹ | 2100 - 2300 |
| Max. Torque | Nm | 1000 |
| At Speed | min ⁻¹ | 1450 |
| Min. Idling Speed | min ⁻¹ | 600 |
| Weight (DIN 70020 Part 7A) | kg | 620 |

DIMENSIONS

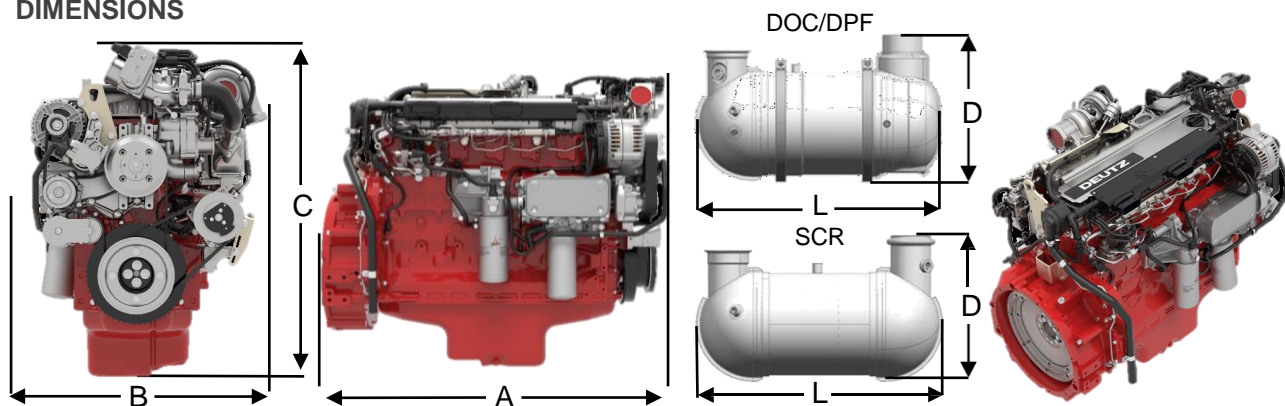

| ENGINE TYPE | | DOC/DPF | | | | SCR | | | | |
|-------------|----|---------|-----|-----|-----|-----|-----|-----|---------|-----|
| | | A | B | C | D | L | D | L | DOC/DPF | SCR |
| TCD 6.1 | mm | 1080 | 724 | 948 | 272 | 782 | 272 | 689 | ● ■ | ● ■ |

- Standard for US Tier 4
- Standard for EU Stage V



DEUTZ AG
 Ottostraße 1
 51149 Cologne
 Germany
www.deutz.com