

DEUTZ G 2.9 L4

Powerful, efficient and compact.



For mobile machinery

The G 2.9 – With 39 up to 54 kW power output ideal for your application.

- **POWERFUL** / Up to 54 kW & 210 Nm
- **LOW EMISSIONS** / EU St. V & US EPA Tier 2* with 3-way catalyst
- **MODULAR** / Wide range of applications due to a variety of options
- **VERSATILE** / LPG (Mono-/Bi - Fuel) & Gasoline (Mono-/ Bi - Fuel)



STAGE **V**
certified

*Only for spark ignition engines

DEUTZ G 2.9

— G 2.9

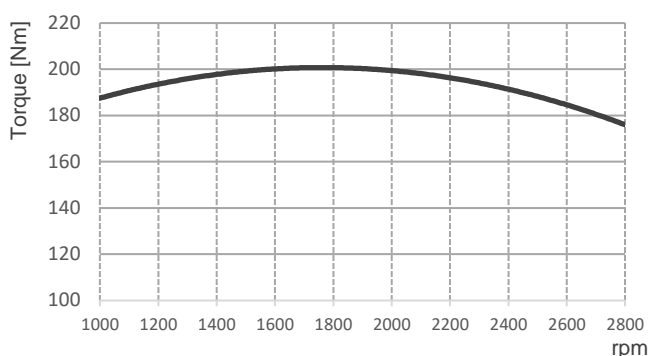
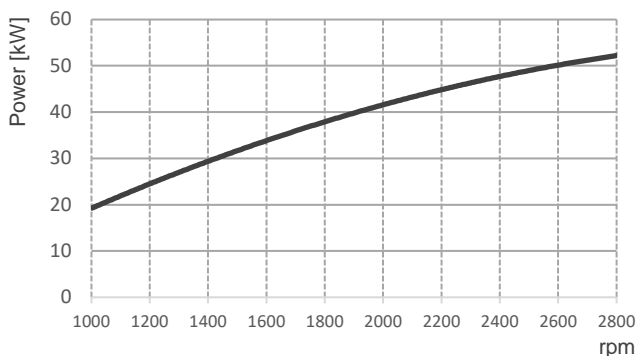

TECHNICAL DATA

ENGINE TYPE	G 2.9	
No. of Cylinders		4
Displacement	l	2.9
Max. Nominal Speed	min ⁻¹	2800
Aspiration		Natural
Power Output acc. ISO 14396	kW	38,9 - 54*
At Speed	min ⁻¹	2800
Max. Torque	Nm	210
At Speed	min ⁻¹	1600
Min. Idling Speed	min ⁻¹	900
Weight (DIN 70020 Part 7A)	kg	270

*depending on fuel type

DIMENSIONS

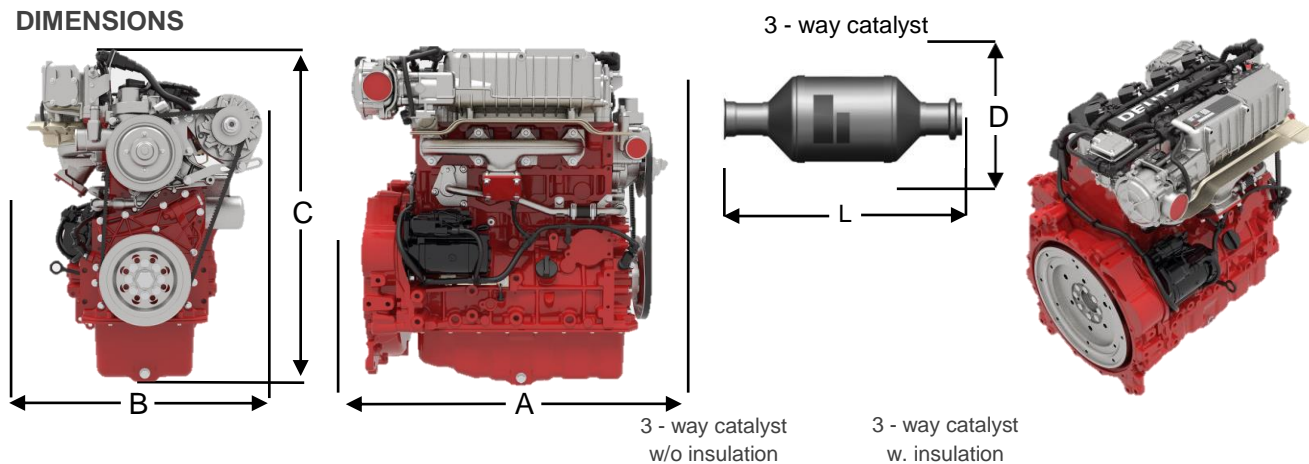

ENGINE TYPE		A	B	C	D	L	D	L	3 - way catalyst
G 2.9	mm	678	572	734	136	400	160	400	● ■

- Standard for US EPA Tier 2
- Standard for EU Stage V

